

FAULT LOCALISATION IN AN MV DISTRIBUTION NETWORK

P.M. VAN OIRSOUW

F. PROVOOST

Phase to Phase - The Netherlands

NUON Technical Projects & Consultancy - The Netherlands

INTRODUCTION

According to the yearly Dutch National Fault Registration Enquiry the largest number of electricity delivery interruptions are caused by faults in the MV networks. Approximately 70 % of all delivery interruptions originate on this voltage level. The restoration time for fault localisation and switching takes averagely 90 minutes. Only 20 % of all delivery interruptions originate in the HV transmission networks. Because of the redundancy in this system and the network automation, these delivery interruptions can be restored quickly. Also only 10 % of all delivery interruptions originate in the LV distribution networks. The restoration in these networks may take a long time, but the number of afflicted customers is small. In order to decrease the average electricity delivery outage time per customer, priority has to be given to the reduction of the restoration time in case of faults in the MV network. One of the main items hereby is the reduction of the fault localisation time.

NUON is one of the large electricity companies in The Netherlands. Its MV distribution systems are constructed with buried cables. Mostly these networks are operated with radial feeders and there are switching possibilities to other feeders. Each feeder is protected in its outgoing feeder bay in the substation and may contain extra protections at splitting points. When a short circuit failure occurs, its location is found after a manual searching operation by checking out all transformer stations along the feeder. The electricity is then restored manually. Thanks to extensive knowledge of the network these interruptions can be restored relatively quickly, but in the near future there will be a growing pressure to shorten the interruption duration even more.

A few years ago it was demonstrated that from the measured voltage and current during the fault an approximation for the fault location could be derived [1]. At that time however the investment costs for such a system (especially event recorders) were too high. However nowadays the digital protection equipment already contains embedded functions for transient recording. These data only needs to be processed in order to calculate the possible fault location directly after the fault has occurred. With this information the personnel should be able to isolate the fault without a time-consuming search operation. Therefore NUON decided to carry out a pilot project in combination with the refurbishment of the Zaltbommel substation. Aim of the project was to reduce the average restoration duration by one hour. The system should pinpoint the fault location within a 100 metres accuracy for two and three phase faults and 1000 metres for single phase faults.

GENERAL SYSTEM DESCRIPTION

In the NUON electricity system the Zaltbommel substation is recently refurbished. In this substation new developed digital protection relays are installed. The system is described in an accompanying paper [2]. The substation consists of two HV bus bars, two HV/MV transformers, two grounding transformers, two MV bus bars and 19 outgoing feeders. The bus bar voltages, the transformer currents and the feeder currents are monitored by the protection system. Besides its normal function of protecting the electricity system, the protection system also transmits the measurements to the dispatch centre in case of a fault. This transmission consists of oscillographic time series measurements of bus phase voltage and faulted feeder phase currents. Also the pre fault values of bus voltage and all feeder currents are transmitted by the system.

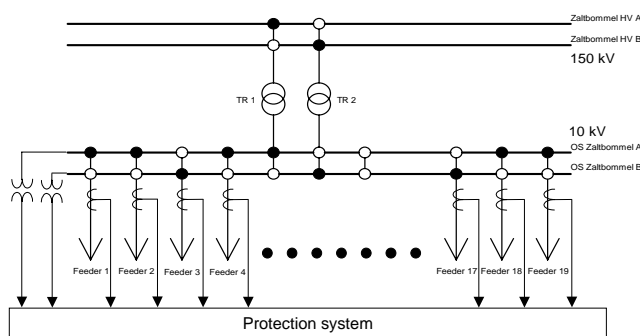

Figure 1 Substation data collection and transmission

All measurement data are transmitted in the Comtrade format. A measurement record is composed of 240 cycles, representing 4.8 s of measured time at 50 Hz. Each cycle is composed of 64 samples. The pre-fault situation is captured in 10 cycles, representing 0.2 s of the measured time. In the case of a fault the protection system transmits the measurement data over a communication link towards the dispatch centre.

In the dispatch centre the measurements are numerically analysed and the impedance from the substation to the fault location is calculated. This value is then compared with the impedance from a simulation on an actual network model. The simulation reveals the location of the fault. NUON and Phase to Phase co-operated in developing this fault localisation system.

METHOD

The principle of fault localisation is quite simple. According to Ohm's law the impedance from a measuring point to a faulted point is determined by the quotient of the meas-

ured voltage and the measured current during the fault. But in practice it is more complicated. It may be important to incorporate the influence of the existing pre fault load current. Also the resistance of the fault itself is not known. Since the reactance of the fault is known to be zero and the cable reactances are well known and not current dependent, the fault locator has to work with the reactance only and the resistance will not be used. According to other publications [3] it is recommended to disregard the resistance part of the fault impedance.

Using the symmetrical components method on a simplified network model, a formula for the fault reactance can be derived for each fault type. This simplified network model consists of a source, an HV/MV transformer, a grounding transformer and a cable connection to the fault location. In this network model five different characteristic component networks represent the five fault types respectively. Figure 2 shows the simplified network and the component networks for a three phase, three phase to ground, two phase, two phase to ground and a single phase fault respectively.

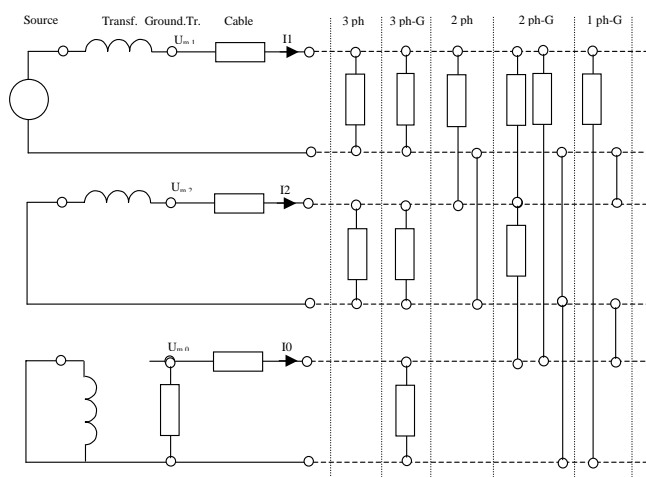

Figure 2 Symmetrical components networks

The reactance formulae are summarised below. In this table the normal reactance ($X_{cable,1}$) and the zero sequence reactance ($X_{cable,0}$) can be calculated from the measured voltages ($U_{m,1}$, $U_{m,2}$ and $U_{m,0}$) and the measured currents (I_1 and I_2) at the time of the fault.

Fault Type	Reactance from substation to fault location
Three phase	$X_{cable,1} = \text{Im}(U_{m,1} / I_1)$
Three phase to ground	$X_{cable,1} = \text{Im}(U_{m,1} / I_1)$
Two phase	$X_{cable,1} = \text{Im}((U_{m,1} - U_{m,2}) / (I_1 - I_2))$
Two phase to ground	$X_{cable,1} = \text{Im}((U_{m,1} - U_{m,2}) / (I_1 - I_2))$
Single phase	$2 X_{cable,1} + X_{cable,0} = \text{Im}((U_{m,1} + U_{m,2} + U_{m,0}) / I_2)$

Assumptions:

- the cable normal and inverse reactances are equal;
- the reactance of the short circuit equals zero.

In case of a single phase fault in a non grounded network the fault current is largely induced by the overall network capacitance and not by the cable impedance from substation to fault location. In this case the fault current is relatively small and the fault will not be switched off. Besides, the LV customers will not notice these kind of faults.

Therefore the proposed method will not be used for single phase faults in non-grounded networks. The method will be used for all two and three phase faults in all network types and for single phase faults in grounded networks only.

The fault localisation procedure consists of two stages. Firstly, the signal has to be analysed in order to find the impedance from the substation to the fault location. Secondly, the calculated impedance has to be compared with the impedance from a simulation on a network model. These two stages are described below.

Signal analysis

The cable reactance from the substation to the fault location will be deducted from the measured time series automatically. In order to do this, the measured time series first have to be transformed into their phase magnitude signals and into their normal, inverse and zero sequence component signals. Hereafter, the algorithm should be able to automatically detect the proper time at which the measured values should be representative for the calculation of the reactance. Then, the fault type should be detected automatically using these representative voltage and current values. A computer algorithm is developed to perform the calculations.

From the measured time series the signal magnitudes are determined using the Digital Fast Fourier Transformation method. Using this method the complex voltage and current time series are generated for the three phases of the faulted feeder. The resulting signals are then transformed into their symmetrical components signals. After this, the next complex signals are available:

- $U_a(t), U_b(t), U_c(t)$: three phase voltage
- $I_a(t), I_b(t), I_c(t)$: three phase feeder current
- $U_0(t), U_1(t), U_2(t)$: zero sequence, normal and inverse voltage
- $I_0(t), I_1(t), I_2(t)$: zero sequence, normal and inverse feeder current

From these transformed signals the samples that are representative for the system state during the fault are detected automatically by analysing the complex phase voltage and phase current signals. The assumption is that all faults and circuit breaker actions generate a transition in the voltage and current signals. Each transition marks the beginning of a new system state. The system state in which the largest short circuit currents occur simply is the state that should provide the voltage and current values for the analysis.

The transitions may include a fading transient behaviour, invoked by system dynamics or short circuit DC signal components. These transients may disturb the calculation. In order to minimise this effect the values are selected at the end of the evaluated system state, just before the next transition should occur. By doing this, the influence of any transients should be negligible. Figure 3 illustrates the process of identifying the representative values for a chang-

ing short circuit fault. In the figure a single phase fault turns into a two phase to ground fault before being switched off. The transitions are:

1. normal state to single phase fault;
2. single phase fault to two phase fault;
3. two phase fault being switched off.

The representative values are those that are the state in which the largest feeder currents occur. The chosen values are those that occur just before transition number three.

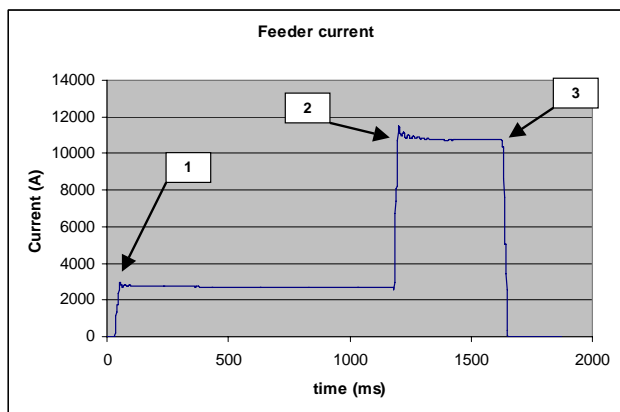

Figure 3 Values selection in case of a changing fault

Now that the representative values are identified, the fault type has to be identified. It is possible to determine the fault type from the symmetrical components currents. Each fault type has a characteristic behaviour relating to the normal, inverse and zero sequence currents. These properties can be derived from the component networks representing the different fault types (figure 2):

- the normal current is larger than the pre fault current ($I_{1,pre}$) in all faulted cases;
- a zero sequence current only flows in case of an asymmetrical fault to ground;
- the normal current minus the pre fault current ($I_{1,pre}$) is much larger only in case of a two or three phase fault;
- an inverse current only flows in case of an asymmetrical fault;
- the inverse current is much larger than the zero sequence current only in case of a two phase fault.

The next table summarises the characteristic properties of the different fault types in the theoretical case:

Fault type	$I_1 > I_{1,pre}$	$I_0 > 0$	$I_2 > 0$	$I_1 - I_{1,pre} \gg I_0$	$I_2 \gg I_0$
1 phase to ground	yes	yes	yes	no	no
2 phase to ground	yes	yes	yes	yes	yes
2 phase	yes	no	yes	yes	yes
3 phase	yes	no	no	yes	no

It is also possible to detect whether an asymmetrical fault occurs in a grounded or a non-grounded network. This can be derived from the quotient of the zero sequence voltage and current, according to the next formula:

$$X = \frac{U_0}{-I_0}$$

It turned out that the absolute value and the phase angle of X strongly depend upon the grounding of the network:

Network type	X [Ohm]	arg(X) [degrees]
grounded	7	90
non-grounded	200	-90

The small value in the grounded network approximately equals the zero sequence reactance of the grounding transformer. The large value in the non-grounded network approximately equals the network capacitance. The inequality should test whether the absolute value of X is larger or smaller than an estimated value of 20 Ohm.

Since the measured signals always contain unpredictable elements, e.g. caused by a specific load or generation behaviour, it is not possible to use an exact technique to determine the fault type. The above table also uses the terms "larger" and "much larger". Using the fuzzy logic technique it should be possible to determine the fault type for these cases. For this technique for each inequality a membership function was defined. This was done by trial and error for a representative set of measurements.

The reactance is calculated for a distance from the measuring point to the fault location. However, the feeder may be split into more than one direction. After a splitting point the feeder is divided into the main feeder and a sub feeder or a dead end feeder. Without any more information the fault location would not be uniquely determined if it would be located behind a splitting point. This extra information can be obtained from the protection time schemes. Each main feeder is protected in the substation using an over-current relay and a circuit breaker. At a splitting point a sub feeder is protected with another over-current relay. A dead end feeder is protected by a fuse. The protection time schemes used by NUON are presented in the next table. In this table the $I >$ threshold is 1.25 times the nominal current and the $I \gg$ threshold is 2000 A for a main feeder and 1500 A for a sub feeder.

Protection	Delay for $I >$	Delay for $I \gg$
Main feeder relay	1.6 s	0.3 s
Sub feeder relay	0.9 s	0.0 s
Dead end feeder fuse	0.0 s	0.0 s

The measured time to switch off the fault is combined with the protection schemes to detect the approximate location in the main feeder, a sub feeder or a dead end. Combining the knowledge of this approximate location with the measured short circuit current and the calculated reactance ultimately reveals the exact location of the fault. In the next stage the exact location is found by comparing this information with a network simulation.

Network model simulation

The result of the previous stage is fed into a network model where the fault is simulated in order to find the exact location. In the simulation process the calculated short circuit currents and voltages are compared with the available measured values. The model uses the pre-fault values for the load and switches adjustment. Figure 4 illustrates the

data flows.

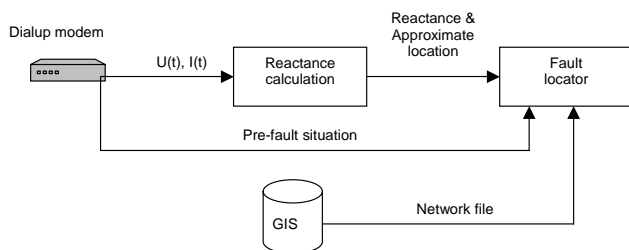

Figure 4 Data flows in the dispatch centre

The network model must reflect the actual situation at all times. All network data are stored in an actual Geographic Information System (GIS). Not only all network nodes and cables are stored in the GIS, but also the actual switch positions in the feeders. Every time a single setting is changed, a new network model is generated automatically by the GIS.

Besides the measured time series, the protection system also provides pre-fault information about the actual feeder bus bar selection in the substation and the pre-fault bus bar voltages and feeder currents. This is done because the actual bus bar selection is not updated in the GIS. The combination of bus bar voltage and feeder currents enables the estimation of the actual load and generation for all feeders.

Once the actual network model is established, the computer program starts simulating short circuits on all nodes in the faulted feeder. Also the information on the approximate location (main/sub/dead end feeder) is used in this step. Depending on the feeder the number of nodes varies from 20 to 60, so this will not be a time consuming process. The short circuit calculations do not use the IEC 909 method but use a full fault analysis method, incorporating actual node voltages and load and generation. This is done because we are not interested in a worst case calculation but in the exact calculation of the short circuit situation. For all short circuit calculations the simulated reactances, as 'seen' from the substation into the direction of the feeder, are calculated. After this step it should be possible to point out two nodes for which the value of the measured reactance lies between the values of the simulated reactances. The last action is to simulate short circuits along the cable connection between the two selected nodes in order to find the distance of the fault.

TESTING THE SYSTEM

The method has been implemented in a computer system in the NUON Central Dispatch Centre. During the pilot project the system works parallel with already installed transient recorders. These recorders were installed for a feasibility study. Prior to the installation the system was tested using the feasibility study recordings since 1997. The system turned out to work good for any three and two phase faults and for single phase faults in a grounded network.

The accuracy depends upon the measuring system, the correct point of time selection for the impedance calculation

and the correct modelling of the normal and zero sequence impedances. The normal impedances are well known. In all tests the automatic detection of the point of time for the impedance calculation worked correctly. Considering the experience for two and three phase faults, where the overall accuracy turned out to be well within the required 100 metres, it could be concluded that the measuring system accuracy is sufficient.

The tests on single phase to ground faults revealed that the correct modelling of the zero sequence impedances is of major importance. These impedances firstly were estimated by experts, using their knowledge from other projects. Later, when transient recordings became available, these estimated values were corrected in the network model.

The next paragraphs illustrate the process of transforming the measured voltage and current time series towards Fast Fourier and Symmetric Components transformed signals for two test signals. The first one for a single phase fault situation and the second one for a single phase fault turning into a two phase fault situation.

Single phase fault

In July 2001 a single phase fault occurred in a dead end feeder. The fault was switched off after 200 ms. There was a remaining current after the switching off. This already leads to the conclusion that the fault should be in a dead end feeder. The calculated reactance from substation to the fault location was 4.6 Ohm, being within the corresponding specified 1000 metres range for $2X_1 + X_0$ in the network model. The first two diagrams show the measured voltages and currents. The decaying DC component can be clearly seen in the currents graph. The next two diagrams show the Fourier transformed voltages and currents. It can be seen that the voltage in the disturbed phase decreased and in the lagging phase increased towards the phase to phase voltage. The short circuit current can clearly be seen, including the diamond in the graph indicating the selected value for the analysis and the reactance calculation. The last two diagrams show the increase in zero sequence voltage. It can be seen that the three symmetric components currents increased.

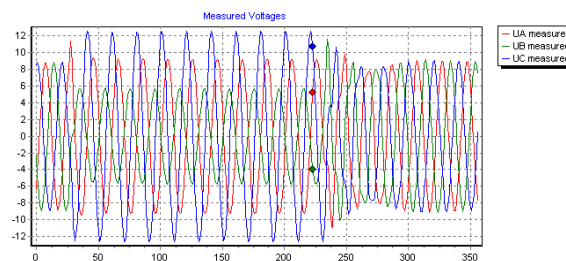

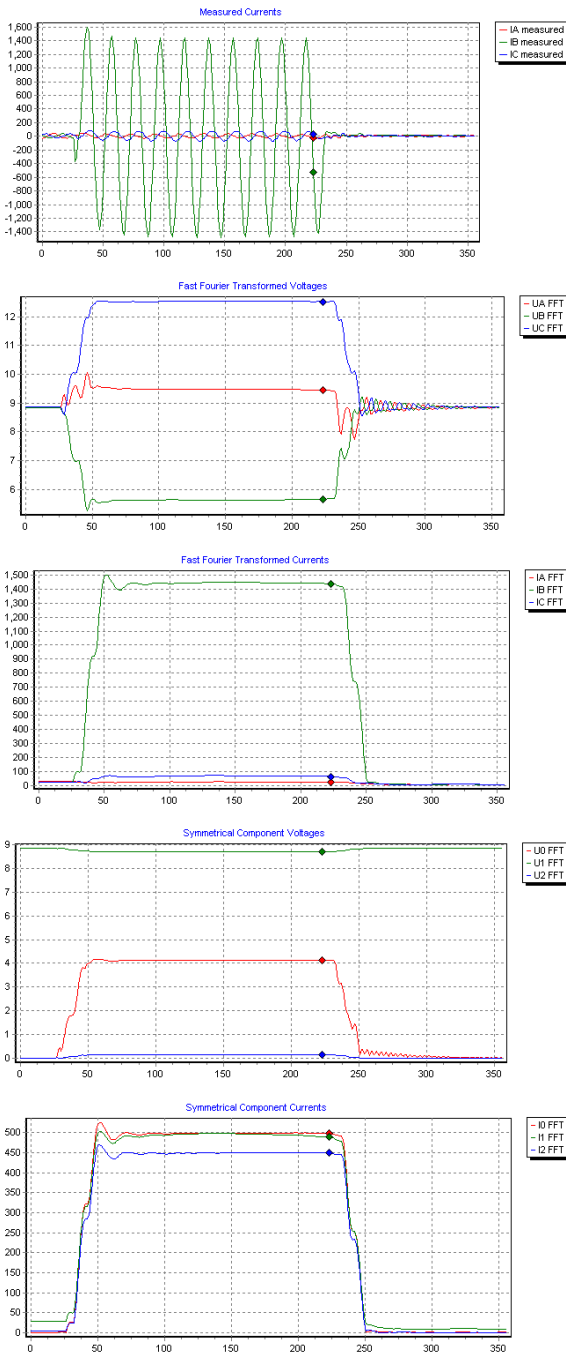

measured voltages and currents. In the current graph a decaying DC component can be seen in the beginning of the single phase fault and in the beginning of the two phase fault. The next two diagrams show the Fourier transformed voltages and currents. It can be seen that the voltage in the disturbed phases decreased. The short circuit currents can clearly be seen, including the diamond in the graph indicating the selected values at the end of the two phase fault state for the analysis and the reactance calculation. The last two diagrams show the increase in zero sequence voltage in the single phase fault state. It can be seen that the three symmetric components currents increased together in the single phase fault state and that both the normal and inverse current components increased in the two phase fault state.

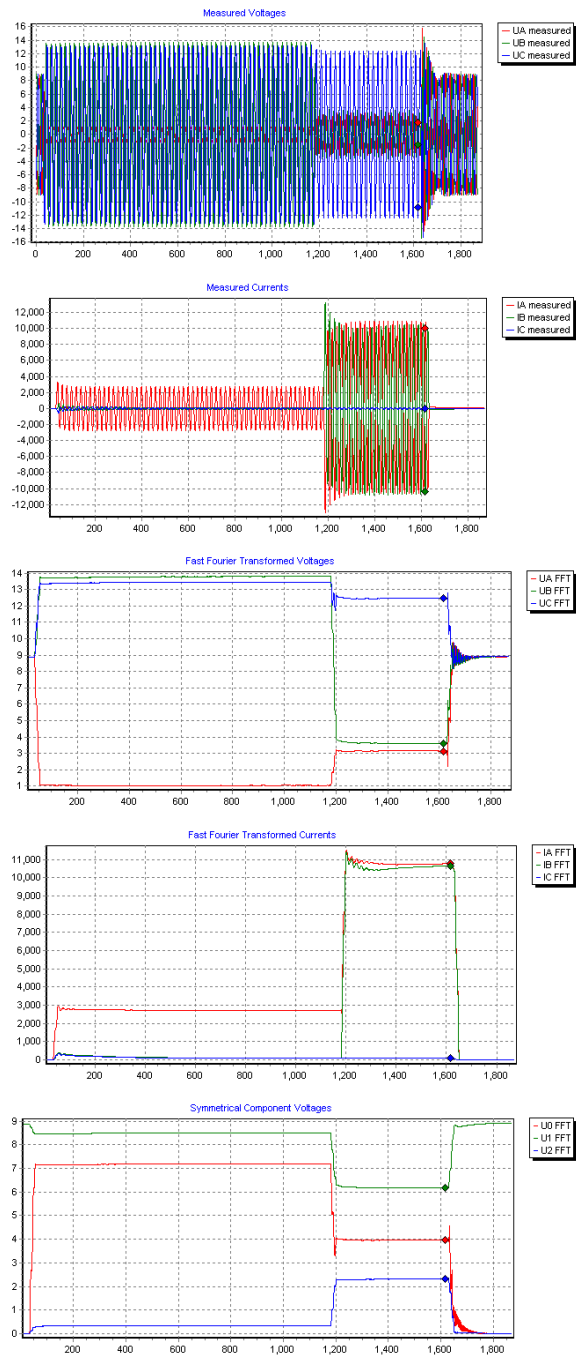

Single phase fault, turning into a two phase fault

In March 1999 a single phase fault occurred in a main feeder just outside the substation. This was caused by digging. This fault migrated into a two phase fault before being switched off. The fault was switched off after 1.6 s. There was no remaining current after the switching off. This already leads to the conclusion that the fault should be located in the main feeder. The calculated reactance from substation to the fault location was 0.309 Ohm, corresponding with the value for X_1 in the network model. Taking into account the value of 0.3 Ohm for the smoothing reactor, one may conclude that the fault should be located very close to the substation. The first two diagrams show the

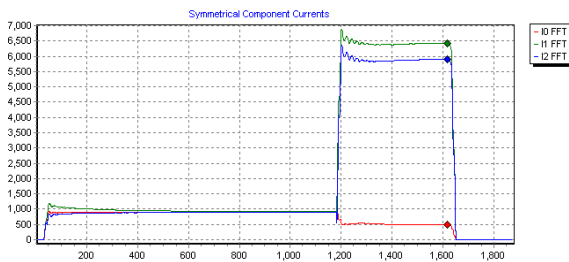

System performance

The developed system runs on a normal Windows PC and it is not very time consuming. Considering a fault event the most time consuming part is collecting and uploading the measured time series. This could take 3 minutes, depending on the priority in the protection system. Once the data is received, the analysis system automatically starts the transformation, fault identification and reactance calculation process. This process takes about 10 seconds. The calculated data, including the pre-fault information on substation switches positions, bus bar voltages and feeder currents, are fed into the second stage process performing the simulations on the network model and identifying the fault location. This process also takes about 10 seconds.

Within 5 minutes after the fault the dispatch centre may instruct the emergency repair crew to check the fault location directly. An estimated one hour of manual searching time may be saved by this method.

Challenge

The tests revealed one main challenge, concerning repetitive single phase faults. Single phase faults in an MV distribution network can occur as the 'heavy ones', causing a lasting short circuit current. These faults will be switched off by the protection equipment. But faults can also occur as the jittering ones, causing short duration (e.g. one or a few cycles) short circuit currents. These faults are self extinguishing and therefore will not always be switched off. In most cases these faults may occur after a small damage to the cable or joint or as a result of water treeing. The jittering may last a few seconds or even a few days before the cable insulation collapses. Even when the distribution system is grounded using a grounding transformer this may lead to a repetitive fault, instead of always being switched off.

The developed fault localisation system is able to calculate the fault reactance even if the fault lasts only two or three cycles. In these cases an indication of the weak point is available. This indication is useful for preventive remedial actions.

During the NUON pilot project several repetitive faults were recorded. It turned out that even in grounded networks single phase to ground faults can self extinguish in a period lasting between half a cycle and half a second and that the

fault can repeat a few seconds later. The magnitude of the fault current during each fault event is large enough to trigger the protection system. The question was how these events would be recorded and communicated to the fault localisation system. It may be possible that the protection system will be busy transmitting the data of an extinguished fault to the dispatch centre and that at the same time a fatal non-extinguishing fault occurs. Because the normal protection function gets all priority, the transmission would be stopped in those cases.

Therefore the challenge is to properly process all the complete and incomplete data that is consecutively sent by the protection system.

CONCLUSION

A fault locating system is developed and tested. It is able to identify the fault location using the measured voltages and currents time series of the fault sequence. The measurements are provided by extra functions in the protection system. The system turned out to be able to identify the fault location within the required accuracy of 100 metres for two and three phase faults and 1000 metres for single phase faults.

The working of the system depends on a good actual network model, so modelling of the normal and zero sequence network impedances require much attention.

The total time for determining a fault location is less than 5 minutes. This time largely depends on the data collection and transmission time from the substation to the dispatch centre. The actual calculation time is less than 20 seconds.

Within 5 minutes after the fault the dispatch centre may instruct the emergency repair crew to check the fault location directly. By using this system NUON may save an estimated one hour of manual searching time.

REFERENCES

- [1] M.M. Saha, F. Provoost: "Fault location in medium voltage networks", *Proceedings CIRED Nice 1999*.
- [2] M. van Riet: "New features during refurbishment of substations", *Proceedings CIRED Barcelona 2003*.
- [3] M. Lethonen, et al: "Automatic Fault Management in Distribution Networks", *Proceedings CIRED Amsterdam 2001*.